

IC 915 LX

NTC-PTC/ P R V-I I-V/ Pt100 Tc

electronic controller with 2 intervention points



BUTTONS AND LEDS

- UP**
Scrolls through the menu items
Increases the values
Parameter programmable
(see par. H31)
- DOWN**
Scrolls through the menu items
Decreases the values
Parameter programmable
(see H32 parameter)
- fnc**
ESC function (quit)
Parameter programmable
(see par. H33)
- set**
Accesses the set point
Accesses the Menus
Activates functions
Confirms the commands
Displays the alarms (if active)
- out 1** **Relay OUT 1**
ON for relay on (energized);blinking
for delay, protection or enabling
blocked.
- out 2** **Relay OUT 2**
ON for relay on (energized);blinking
for delay, protection or enabling
blocked.
- Alarm**
ON for active alarm; blinking for
silenced alarm
- Soft Start (and Set Point setting)**
ON for reduced Set Point;
blinking when Soft Start function is
on;

MACHINE STATUS MENU

a) Press the 'set' button and release it to access the machine status menu. In normal conditions, the labels for the two Set point values are found in the menu. Once the 'SP1' label has been displayed, press the "set" button to display the Setpoint 1 value. The Setpoint 1 value appears on the display. To change the Set point

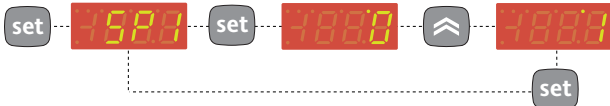

value, use the "UP" and "DOWN" buttons within 15 seconds. If you press the "set" button again, when the fnc button is pressed or 15 seconds elapse, the last value displayed will be stored and the "SP1" label will reappear on the display. To set the Setpoint 2 value, follow the same procedure for setting Setpoint 1.

b) If alarms are present, the "AL" label appears. By using the "UP" and



"DOWN" buttons, you can scroll through all the folders in the menu:
-AL: alarm folder (if alarms present, except for faulty probes/probe errors;
-SP1: Set point 1 setting folder.
-SP2: Set point 2 setting folder.

c) If an alarm condition exists when the Machine Status menu is accessed, the "AL" folder label appears.



(example: when maximum and minimum temperature alarms are present)

Use the UP and DOWN buttons to scroll through the list of active alarms and press 'set' to display the selected alarm.

PROGRAMMING MENU

The menu is divided into 2 levels once users have pressed the 'set' button for 5 seconds, they can access the user level folders (1)

Navigation at user level(1):

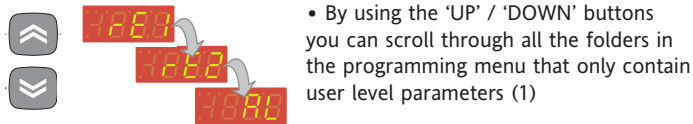

- By using the 'UP' / 'DOWN' buttons you can scroll through all the folders in the programming menu that only contain user level parameters (1)

How to access the installer level (2):

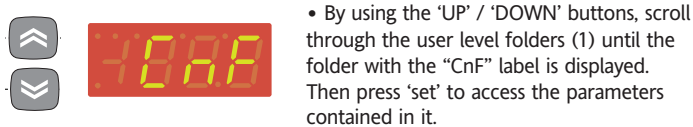

- By using the 'UP' / 'DOWN' buttons, scroll through the user level folders (1) until the folder with the "CnF" label is displayed. Then press 'set' to access the parameters contained in it.

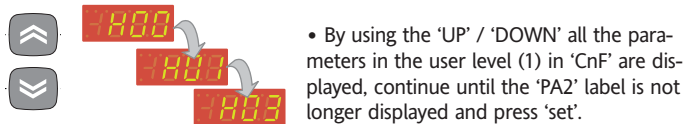

- By using the 'UP' / 'DOWN' all the parameters in the user level (1) in 'CnF' are displayed, continue until the 'PA2' label is not longer displayed and press 'set'.



- By pressing the 'set' button next to 'PA2' the first folder containing installer level parameters will be displayed and then the 'rE1' folder.

Navigation at installer level(2):



- By using the 'UP' / 'DOWN' buttons you can scroll through all the folders in the programming menu that only contain installer level parameters (2)

How to modify the parameter value (on both levels):



- When the 'set' button is pressed, the first folder in the menu is displayed. (e.g.: "rE1" folder)



- By using the 'UP' / 'DOWN' buttons you can scroll through all the folders in current level.



- By pressing the 'set' button next to the selected folder (in this case "AL") the first parameter in the current level will be displayed. Select the desired parameter using the 'UP' / 'DOWN' keys.



- By pressing the 'set' button the value of the selected parameter is displayed and by using the 'UP' and 'DOWN' buttons, it can be modified.

PASSWORD

Access to parameter handling both at user level and installer level can be limited by using passwords. The passwords can be enabled by setting the PA1 (user password) and PA2 (installer password) in the 'dis' folder. The passwords are enabled if the value of the 2 parameters PA1 and PA2 is not 0.

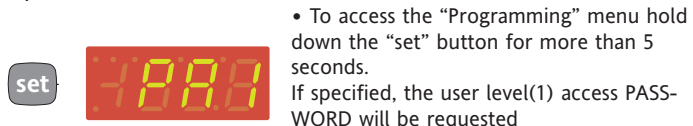

- To access the "Programming" menu hold down the "set" button for more than 5 seconds.
If specified, the user level(1) access PASSWORD will be requested



- If password 1 is enabled (not 0) you will be asked to enter it. Perform the operation by selected the correct value using the 'UP' e 'DOWN' keys and press the 'set' button to confirm.

Installer level (2) parameters

In the programming menu scroll through the folders containing the user level parameters using the UP' and 'DOWN' buttons until the CnF folder is displayed.



• Press the 'set' button to enter the 'CnF' folder where the 'PA2' label is present.



• Scroll through the folder parameters and press the 'set' button next to the 'PA2' label, '0' will appear on the display.



• Use the 'UP' / 'DOWN' buttons to select the correct value of the installer password and then press the 'set' button to access the installer level parameters (2).

If the password is not entered correctly, the device will display the 'PA2' label again and the operation will have to be repeated.

At each level in both menus, when the "fnc" button is pressed or the 15 second time out elapses, you are taken back to the higher display level and the last value on the display is stored.

COPY CARD

The Copy Card is an accessory connected to the TTL serial port used for quick programming of the unit parameters (upload and download parameter map to one or more units of the same type). upload (UL label), download (dL label) and copy card formatting (Fr label) operations are performed in the following way:



• The 'FP' folder contains the commands necessary for use of the Copy Card. Press 'set' to access the functions.



• Use the 'UP' / 'DOWN' buttons to display - the required function. Press the 'set' and uploading (or downloading) will be performed.



• If the operation is successful 'y' will be displayed, if it is not successful, 'n' will be displayed.

Download from reset

Connect the copy card when the instrument is OFF. The programming parameters are downloaded when the device is switched on. At the end of the lamp test, the following messages are displayed for about 5 seconds:

- dLY label if copy operation is successful
- DLn label if operation fails

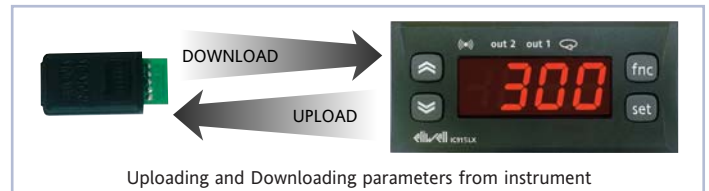

NOTE:

- after the parameters have been downloaded, the device uses the downloaded parameter map settings.
- see "FP" folder" in Parameter Table and Description of parameters

FUNCTIONS

The following functions are available in the FnC folder (last folder visible from the Programming Menu, level 1):

Function	Function label ACTIVE	Function label NOT ACTIVE	D.I.	Button	Active function signalling
soft start	SO _n	SO _F *	1	1	LED blinking
economy set point	OSP	SP*	2	2	LED ON
shut-down?	bO _n *	bO _F	3	3	LED ON
periodic cycle	CO _n	CO _F	4	4	LED ON
aux	AO _n	AO _F	5	5	LED ON
stand-by.	O _n *	O _F	6	6	LED ON
maintenance request	A _{tn}	A _{tF} *	7	7	UnP blinking

* indicates default

NOTE: to modify the status of a specified function press the 'set' button

NOTE: If the unit is switched off, the function labels go back to their default status.

ALARMS

LABEL	ALARM	CAUSE	EFFECTS*	Resolving problems	IC 915 LX MODELS		
					NTC/PTC	V-I	Pt100-Tc
E1	Probe 1(control) faulty	<ul style="list-style-type: none"> • measuring of values outside the nominal reading range • control probe faulty/shorted/open probe 	"E1" label appears on display; Controller enabled as indicated by the On1 and OF1 parameters if programmed for the Duty Cycle	<ul style="list-style-type: none"> • check the probe wiring • replace the probe 	●	●	●
AH1/AH2	High temperature alarm	<ul style="list-style-type: none"> • value read by probe 1 > HA1/2 after time equal to "tAO". (see "MIN MAX ALARMS" and description of "HA1/2", "Att" and "tAO" parameters) 	Alarms created in the "AL" folder with the AH1/AH2 label	<ul style="list-style-type: none"> • Wait for temperature value read by probe 1 to fall below HA1/2 	●		●
AL1/AL2	Low temperature alarm	<ul style="list-style-type: none"> • value read by probe 1 < LA1/2 after time equal to "tAO". (see "MIN MAX ALARMS" and description of "LA1/2", "Att" and "tAO" parameters) 	Alarms created in the "AL" folder with the AL1/AL2 label	<ul style="list-style-type: none"> • Wait for temperature value read by probe 1 to go above LA1/2 	●		●
EA	External alarm	<ul style="list-style-type: none"> • control of alarm from active D.I. if "H11" = 8 or 9 (see description of "H11" parameter) 	Alarms signalled in the "AL" folder with the EA label It only blocks the controllers if "H11"=9	<ul style="list-style-type: none"> • Manual silencing by pressing button 	●		●

* Effects common to all alarms: Alarm LED permanently on; Buzzer activated (if present); Relay enabled (if configured as alarm "H21"=3)

MAX-MIN ALARMS

Temperature expressed as an absolute value (par "Att"=0) Abs(olute)

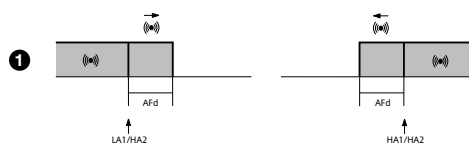

Minimum temperature alarm	Temperature lower than or equal to LA1/2 (LA1/2 with sign)
Maximum temperature alarm	Temperature greater than or equal to HA1/2 (HA1/2 with sign)
Minimum temperature alarm back swing	Temperature higher than or equal to LA1/2+AFD
Maximum temperature alarm back swing	Temperature lower than or equal to HA1/2-AFD

Temperature in relation to set point (par "Att"=0) rEL(ative)

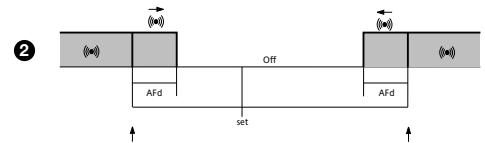

Temperature lower than or equal to set point +LA1/2 (LA1/2 positive only)
Temperature lower than or equal to set point +HA1/2 (HA1/2 positive only)
Temperature greater than or equal to set point + LA1/2 + AFD
Temperature greater than or equal to set point - LA1/2 +AFD
Temperature lower than or equal to set point+HA1/2-AFD

if Att=rEL(ative) LA1/2 must be negative: therefore set point+LA1/2<set point because set point+(-|LA1/2|)=set-|LA1/2|

PARAMETER TABLE

	PAR.	RANGE	DEFAULT	LEVEL	U.M.
	SP1	LS1...HS1	0.0		°C/°F
	SP2	LS2...HS2	0.0		°C/°F
Controller 1-rE1 label	HC1	H/C	H/C*	1	Flag
	OS1	-30.0...30.0	0	2	°C/°F
	db1	0...30.0	1*	1	°C/°F
	dF1	0...30.0	0*	1	°C/°F
	HS1	LS1...HdL	*	1	°C/°F
	LS1	LdL...HS1	*	1	°C/°F
	HA1	LA1...150.0	*	1	°C/°F
	LA1	-150.0...HA1	*	1	°C/°F
	dn1	0...250	1	1	°C/°F
	dO1	0...250	0	1	sec
	di1	0...250	0	1	min
	dE1	0...250	0	1	min
On1	0...250	0	1	sec	
OF1	0...250	1	1	min	
Controller 2-rE2 label	HC2	H/C	H/C*	1	Flag
	OS2	-30.0...30.0	0	2	°C/°F
	db2	0...30.0	1*	1	°C/°F
	dF2	0...30.0	0*	1	°C/°F
	HS2	LS1...HdL	*	1	°C/°F
	LS2	LdL...HS1	*	1	°C/°F
	HA2	LA1...150	*	1	°C/°F
	LA2	-150...HA1	*	1	°C/°F
	dn2	0...250	1	1	°C/°F
	dO2	0...250	0	1	sec
	di2	0...250	0	1	min
	dE2	0...250	0	1	min
On2	0...250	0	1	sec	
OF2	0...250	1	1	min	
Sft label	dSi	0...25.0	0	2	°C/°F
	dSt	0...250	0	2	hh/mm/sec
	Unt	0/1/2	0	2	hh/mm/sec
	SEn	0/1/2/3	0	2	num
cLc label	Con	0...250	0	2	min
	Cof	0...250	0	2	min
Alarms-AL label	Att	AbS/rEL	AbS	2	flag
	Afd	1.0...50.0	2.0	2	°C/°F
	PAO (1) (!)	0...10	0	1	°C/°F
	SAO	0...10	0	1	hours
	tAO (1)	0...250	0	2	min
AOP	nc/no	nc/no	2	flag	
Add label	dEA (!)	0...14	0	1	num
	FAA (!)	0...14	0	1	num
Display-diS label	LOC	n/y	n	1	flag
	PA1	0...250	0	1	num
	PA2 **	0...250	0	2	num
	ndt	n/y	n	1	flag
	CA1	-30.0...30.0	0	1	°C/°F

	PAR.	RANGE	DEFAULT	LEVEL	U.M.		
Display - diS label	CAI		0/1/2	2	2	num	
	LdL	IC 915 LX NTC/PTC	-67.0...HdL	-50	2	°C/°F	
		IC 915 LX V-I	-99...HdL	*			
		IC 915 LX Pt100-Tc	-328...HdL	*			
	HdL	IC 915 LX NTC/PTC	LdL...302	140	2	°C/°F	
		IC 915 LX V-I	LdL...100	*			
IC 915 LX Pt100		LdL...1999	*				
dro	IC 915 LX NTC/PTC	°C/°F	°C	1	flag		
	IC 915 LX Pt100						
Configuration- CnF label	H00 (!)	IC 915 LX NTC/PTC	PtC/ntC	PtC/ntC*	1	flag	
		IC 915 LX V-I	420/020/010/05/01	*		num	
		IC 915 LX Pt100-Tc(2)	Pt1/JtC/HtC	Pt1/JtC/HtC*		num	
	H01		0/1/2	0/1/2*	1	num	
	H03	IC 915 LX V-I	(ndt=y)	-99.0...100.0	*	1	°C/°F
			(ndt=int)	-990...1000			
	H04	IC 915 LX V-I	(ndt=y)	-99.0...100.0	*	1	°C/°F
			(ndt=int)	-990...1000			
	H05		-2/-1/0/+1/-2	0	2	num	
	H06		n/y	y	2	flag	
	H08		0/1/2	2	2	num	
	H10		0...250	0	1	min	
	H11	IC 915 LX NTC/PTC	IC 915 LX Pt100-Tc	0...9	0	2	num
	H13	IC 915 LX NTC/PTC	IC 915 LX Pt100-Tc	no/nc/noP/nCP	no	2	num
H14	IC 915 LX NTC/PTC	IC 915 LX Pt100-Tc	0..0.250	0	2	num	
H21		0...6	1	2	num		
H22		0...6	1	2	num		
H31		0...7	0	2	num		
H32 (!)		0...7	0	2	num		
H33 (!)		0...7	0	2	num		
rEL		/	/	1	/		
tAb		/	/	1	/		

PA2 label

In the CnF folder you can access all level 2 parameters with the PA2 label by pressing the "set" button

FPr label				
UL	/	/	1	/
dL	/	/	1	/
Fr (3)	/	/	2	/

FUNCTIONS (folder with "FnC" label)

The FnC folder (last folder visible from the Programming Menu) contains several functions that are activated using the "set" button.

NOTES:

- (1) Refers exclusively to high and low temperature alarms.
- (2) The Pt100 model only works for the Pt100 input (3 wires) whereas Tcj/TcK models, on the basis of this parameter, can work with the Tc input and the Pt100 input.
- (3) If the Fr command is used, the data entered in the card will be permanently lost. This operation cannot be undone. After the operation with the Copy Card, the controller must be switched off and then switched back on

WARNING (!)

If one or more parameters marked with (!) are modified, the controller must be switched off after the modification and then switched back on

PLEASE NOTE:

The parameters dro, H11, H13 and H14 are only present in models IC 915 LX NTC/PTC and Pt100/Tcj-TcK.

Parameters H03 and H04 are only present in the IC 915 LX V-I model

* The default value depends on the model

** Visible at level 1 in the CnF folder and can be set at level 2 in the diS folder

DESCRIPTION OF PARAMETERS

CONTROLLER 1/CONTROLLER 2 (folders with “rE1”/“rE2” label)

HC1/HC2	If set to H, the controller operates in heating mode. If set to C, the controller operates in cooling mode.
OS1/OS2	Offset Setpoint 1/Offset Setpoint 2
db1/db2	Operating band 1, 2 See ON-OFF control diagram
dF1/dF2	Relay 1 intervention differential. The load will stop when Set point 1 is reached (as indicated by the control probe) and will restart at a temperature equal to setpoint 1(2) plus (or minus, depending on HC1/HC2) the value of the differential. See ON-OFF adjustment diagram
HS1/HS2	Maximum value for set point 1/2.
LS1/LS2	Minimum value for set point 1/2.
HA1/HA2	Maximum alarm OUT 1/OUT 2 See Max/Min. Alarm diagram
LA1/LA2	Minimum alarm OUT 1/OUT 2 See Max/Min. Alarm diagram .

PROTECTIONS CONTROLLER 1/PROTECTIONS CONTROLLER 2 (folders with “rE1”/“rE2” label)

dn1/dn2	Start-up delay. The specified time must elapse between the controller relay start-up request and actual start-up.
do1/do2	Delay after shut-down. The specified time must elapse between shut-down of the controller 1/2 relay and a subsequent start-up
di1/di2	Delay between start-ups. The specified time must elapse between two subsequent start-ups of controller 1/2.
dE1/dE2	Shut-down delay. The specified time must elapse between shut-down of the controller 1/2 relay and a subsequent start-up NOTE: for parameters dn1, dn2, do1, do2, di1, di2, dE1 0= not active
On1/On2	Controller start-up time if probe is faulty. If set to “1” with Oft at “0” the controller is always on whereas if Oft >0 it operates in duty cycle mode.
OF1/OF2	Controller shut-down time if probe is faulty. If set to “1” with Ont at “0” the controller is always on whereas if Ont >0 it operates in duty cycle mode.

SOFT START (folder with “Sft” label)

N.B.: The SOFT START function is button, D.I. or function selectable.

The Soft Start controller can be used to set the temperature gradient required to reach a specific set point in a specific period of time. This function automatically gives you a progressive increase of the control set point from the Ta value (ambient temperature at start-up) to the value actually displayed. This means that a rise in temperature can be immediately stopped and the risk of overshooting reduced.

dSi	Value (in degrees) of each of subsequent increases (dynamic) of adjustment point.? 0=disables the SOFT START function.
dSt	Time between two subsequent increases (dynamic) of set point
Unt	Unit of measurement (hours, minutes, seconds)
SEn	Enabled outputs. Establishes which outputs the function must be enabled on: 0 = disabled; 1 = OUT 1; 2 = OUT 2; 3 = OUT 1 & 2;
Sdi	Function reinsertion threshold. Establishes the threshold beyond which the SOFT START function is automatically re-inserted

PERIODIC CYCLE (folder with “cLc” label)

N.B.: The PERIODIC CYCLE function is button, D.I. or function selectable.

This function can be associated with relay outputs (by setting parameters H21, H22 =4) and can be used for “Duty Cycle” adjustment with the ranges defined by the parameters Con and CoF

Con	Output ON time.
CoF	Output OFF time.

ALARMS (folder with “AL” label)

Att	Parameter “HA1/2” and “LA1/2” modes, as absolute temperature values or as differential compared with? the Set point. 0 = absolute value; 1 = relative value.
AFd	Alarm differential.
PAO	Alarm exclusion time on device start-up after a power failure.
SAO	Alarm exclusion time after reaching the Set point. 0 = disabled. If >0, an alarm will be generated if the Set point is not reached after the time (in hours) set by this parameter.
tAO	Temperature alarm signal delay time.
AOP	Polarity of alarm output. 0 = alarm active and output disabled; 1 = alarm active and output enabled.

COMMUNICATION (folder with “Add” label)

dEA	Device address: indicates the device address to the management protocol.
FAA	Family address: indicates the device family to the management protocol.

DISPLAY (folder with “diS” label)

Keyboard Lock

Keyboard operating can be locked by programming the “Loc” parameter (see folder with “diS” table). If the keyboard is locked you can access the Programming Menu by pressing the “set” button. The Set point can also be displayed.

LOC Keyboard locked (set point and buttons). However, you can still access the parameter programming menu and modify the parameters including the status of this parameter to allow keyboard unlocking. y = yes; n = no.

PA1	Password 1. When enabled (value is not 0) it represents the access key to level 1 parameters.
PA2	Password 2. When enabled (value is not 0) it represents the access key to level 2 parameters.
ndt	number display type. Display with decimal point. y = Yes; n = no.
CA1	Calibration 1. Positive or negative temperature value that is added to the value read by control probe (probe 1) before being displayed or used for control.
CAI	Offset intervenes on display, thermostat control or both. 0 = only modifies the temperature displayed 1 = adds to the temperature used by controllers not the temperature displayed that remains unchanged; 2 = adds to temperature displayed that is also used by the controllers
LdL	Minimum value the instrument is able to display.
HdL	Maximum value the instrument is able to display.
dro	Select °C or °F to display temperature read by probe. N. B.: switching from °C to °F or vice versa DOES NOT modify set points, differentials, etc. (e.g. set point=10°C becomes 10°F)

CONFIGURATION (folder with “CnF” label)

H00	Selection of probe type.
H01	Output link. 0 = independent; 1 = dependent; 2 = Neutral Area (or window)
H02	Button activation time if buttons are configured for a second function. For the ESC, Up and DOWN buttons configured for a second function (defrost, aux, etc) the time for quick enabling is set. Fa Aux is an exception and has a set time of 1 second
H03	Minimum value of current input
H04	Maximum value of current input
H05	Window filter. -2=very fast; -1=fast; 0=normal; 1=slow; 2=very slow
H06	button/aux input/door switch light active when instrument is off (but powered)
H08	Stand-by operating mode. 0= only display is switched off; 1= display on and controllers disabled; 2= display off and controllers disabled;
H10	Output delay from power-on Attention! If = 0 is not active; if ≠ 0 the output will not be activated before this time has expired
H11	Configuration of digital inputs 0 = disabled; 1 = SOFT START; 2 = Set point Offset; 3 = outputs shut down; 4 = periodic cycle; 5 = auxiliary output; 6 = stand-by; 7 = maintenance request 8 = external alarm 9 = external alarm disables controllers.
H13	Polarity and priority Digital Input no= normally open/ nc= normally closed / noP= normally open with polarity / ncP= normally closed with polarity see “H13 parameter configuration” table
H14	Digital input enabling delay
H21	Digital output configurability 1 (OUT1) 0 = disabled; 1 = on-off 2 = not used; 3 = alarm; 4 = periodic cycle 5 = aux 6 = stand-by
H22	Digital output 2 configurability. (OUT2) Same as H21.
H31	UP button configurability. 0 = disabled; 1 = SOFT START; 2 = Set point Offset; 3 = outputs shut down; 4 = periodic cycle; 5 = auxiliary output (aux); 6 = stand-by; 7 = maintenance request
H32	DOWN button configurability. Same as H31.
H33	fnc button configurability. Same as H31.
rEL	Device version. Read only parameter.
tAb	Reserved. Read only parameter.
	COPY CARD (folder with “Fpr” label)
UL	UpLoad: transfer of programming parameters from instrument to Copy Card.
dL	downLoad: transfer of programming parameters from Copy Card to device.
Fr	Format. Cancelling all data entered in the copy card. N.B.: if the “Fr” parameter is used (copy card formatting) the data entered in the card will be permanently lost. This operation cannot be undone. After the operation with the Copy Card the controller must be switched off and then on again

ON-OFF CONTROL DIAGRAM

HC1	HC2	H01	type of regulation
H	C	0	independent set points
H	C	1	dependent set points
-	-	2	Neutral Area (or window)

NOTE: examples with HC1=H and HC2=C

independent ON-OFF control diagram. The two outputs regulate as though they are completely independent

1

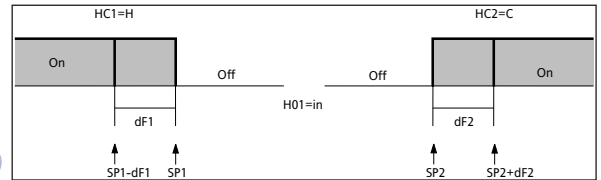

dependent ON-OFF control diagram. The set point 2 SP2 regulates according to SP1

2

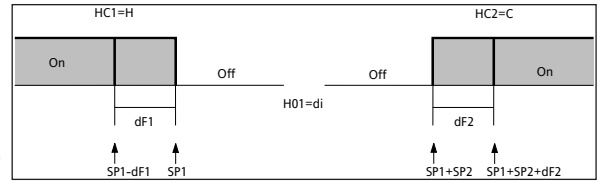

ON-OFF control diagram Neutral Area (or window). NOTE: if df1 and df2 are both =0 the outputs are deactivated when SP1 is reached

3

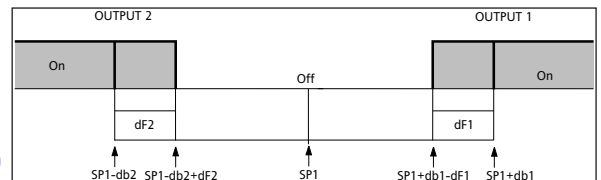

H13 PARAMETER CONFIGURATION

H13	D.I. STATE	WITH BUTTON OR MENU		FUNCTION STATE	COMMENTS
		ENABLED	DISABLED		
NO	open	YES	YES	ON	enabled/disabled with each mode
NO	closed	YES	YES	OFF	enabled/disabled with each mode
NC	open	YES	YES	OFF	enabled/disabled with each mode
NC	closed	YES	YES	ON	enabled/disabled with each mode
NOP	open	YES	YES	ON	enabled only from D.I. / disabled with each mode
NOP	closed	NO	N/A	OFF	enabled only when D.I. / is reopened
NCP	open	YES	YES	OFF	enabled with each mode / disabled only from D.I.
NCP	closed	N/A	NO	ON	enabled with each mode / disabled only from D.I.

EWPA-EWHS PROBES CONFIGURATION

● EWHS 280 2 fili

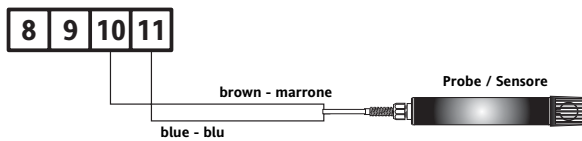

● EWPA 007/030 2 fili / Trasduttore

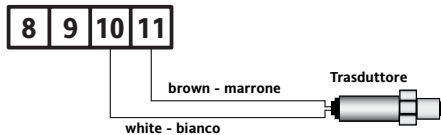

● EWHS 300/310 3 fili

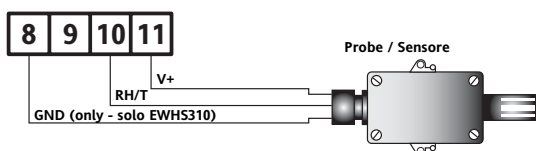

● EWHS 310 4 wires

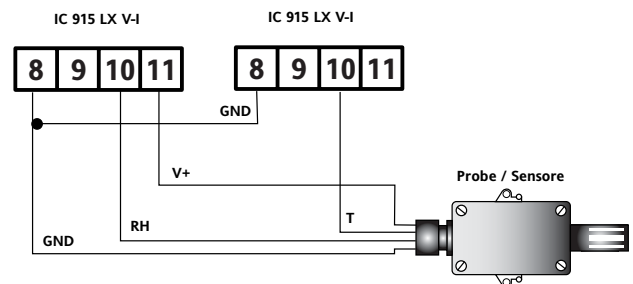

TECHNICAL DATA

IC 915 LX NTC/PTC

Front protection	IP65	IP65	IP65
Casing	PC+ABS plastic resin body PC+ABS UL94 V-0 polycarbonate front, thermoplastic resin buttons	PC+ABS plastic resin body PC+ABS UL94 V-0 polycarbonate front, thermoplastic resin buttons	PC+ABS plastic resin body PC+ABS UL94 V-0 polycarbonate front, thermoplastic resin buttons
Dimensions	front keypad 74x32 mm, depth 59mm (excluding terminals)	front keypad 74x32 mm, depth 59mm (excluding terminals)	front keypad 74x32 mm, depth 59mm (excluding terminals)
Assembly	each panel with drilling template 71x29mm (+0.2/-0.1mm)	each panel with drilling template 71x29mm (+0.2/-0.1mm)	each panel with drilling template 71x29mm (+0.2/-0.1mm)
Operating temperature	-5°C...55°C	-5°C...55°C	-5°C...55°C
Storage temperature	-30°C...85°C	-30°C...85°C	-30°C...85°C
Ambient operating and storage humidity	10...90% RH (non-condensing)	10...90% RH (non-condensing)	10...90% RH (non-condensing)
Display range	NTC: -50...110°C (-58...302°F) / PTC: -50...140°C (-58...302°F) on display 3 1/2 digits plus sign	-99...100 (ndt=n), -99...100.0 (ndt=y), -999...1000 (ndt=imt) on display 3 1/2 digits plus sign	Pt100: -150...650°C / Tcj: -40...750°C / Tck: -40...1350°C* on display 3 1/2 digits plus sign
Analogue input	1 NTC or 1 PTC (parameter selectable)	1 V-I (0-1V, 0-5V, 0-10V, 0-20...mA, 4...20mA par.H00)	1 Pt100 or 1 Tcj or Tck (depending on model)
Serial	TTL for connection to Copy Card or TelevisSystem	TTL for connection to Copy Card and TelevisSystem	TTL for connection to Copy Card or TelevisSystem
Digital outputs (configurable)	1 SPDT 8(3)A 1/2 hp 250 V~ 1 on SPST relay 8(3)A 1/2 hp 250 V~	1 SPDT relay 8(3)A 1/2 hp 250 V~ 1 SPST relay 8(3)A 1/2 hp 250 V~	1 SPST relay 8(3)A 1/2 hp 250 V~ 1 on SPST relay 8(3)A 1/2 hp 250 V~
Buzzer output	only in specific models from	only in specific models from	only in specific models from
Measurement range	-50 to 140°C	-999 to 1000 better than 0.5% of full scale value + 1 digit	-150 to 1350
Accuracy	better than 0.5% of full scale value + 1 digit	1 or 0.1 digits depending on parameter settings	see "Pt100/Tcj/Tck models" table
Resolution	0.1°C (0.1°F up to +199.9°F; 1°F over)	1.5 VA max(mod. 12V) / 3 VA max (mod. 230V)	see "Pt100/Tcj/Tck models" table
Power consumption	1.5 VA max(mod. 12V) / 3 VA max (mod. 230V) 12V~/f _{res} , 12/24 V~/f _{res} , 24V~/f _{res} 10%, 110/115V~, 220/230 V~ 10% 50/60 Hz	12V~/f _{res} , 12/24 V~/f _{res} , 24V~/f _{res} 10%, 110/115V~, 220/230 V~ 10% 50/60 Hz	1.5 VA max(mod. 12V) / 3 VA max (mod. 230V) 12V~/f _{res} , 12/24 V~/f _{res} , 24V~/f _{res} 10%, 110/115V~, 220/230 V~ 10% 50/60 Hz
Power supply	110/115V~, 220/230 V~ 10% 50/60 Hz	110/115V~, 220/230 V~ 10% 50/60 Hz	110/115V~, 220/230 V~ 10% 50/60 Hz

WIRING DIAGRAM

12 V model

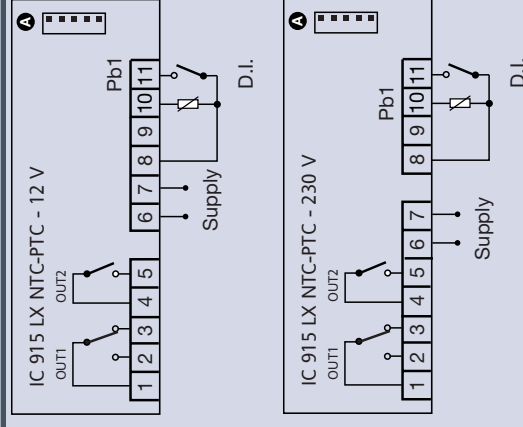

230 V model

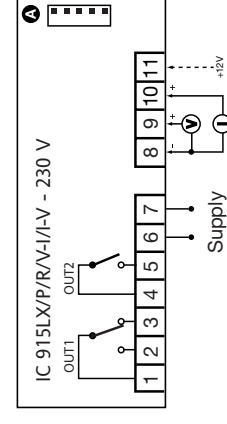

Terminals

1-2	N.O. controller relay OUT1	1-2	N.O. controller relay OUT1
1-3	N.C. controller relay OUT1	4-5	N.O. controller relay OUT2
4-5	N.O. controller relay OUT2	6-7	Power supply
6-7	Power supply	8-9	Digital input D.I.
8-10	Pb1 probe input (control)	*10-11-12	Probe input Pt100 3 wires Pb1
8-11	Digital input D.I.	*11-12	Tcj/Tck input
A	TTL input for Copy Card and connection to TelevisSystem	A	TTL input for Copy Card and TelevisSystem

Pt100/ Tc/ TcK MODELS

Pt100:

Accuracy:

0.5% for full scale value + 1 digit;
0.2% from -150 to 300°C

Resolution:

0.1°C (0.1°F) up to 199.9°C; 1°F over

Tc:

Accuracy:

0.4% for full scale value + 1 digit;

Resolution:

1°C (1°F)

TcK:

Accuracy:

0.5% for full scale value + 1 digit;
0.3% from -40 to 800°C

Resolution:

1°C (1°F)

RESPONSIBILITY AND RESIDUAL RISKS

Eliwell shall not be liable for any damages deriving from:

- installation/use other than that prescribed and, in particular, which does not comply with the safety standards specified in the regulations and/or those given herein;
- use on boards which do not guarantee proper protection against electric shock, water or dust when assembled;
- use on boards which allow dangerous parts to be accessed without the use of tools;
- tampering with and/or alteration of the product;
- installation/use on boards that do not comply with the standards and regulations in force.

DISCLAIMER

This document is exclusive property of Eliwell and cannot be reproduced and circulated unless expressly authorized by Eliwell. Although Eliwell has taken all possible measures to guarantee the accuracy of this document, it declines any responsibility for any damage arising out of its use. The same applies to any person or company involved in preparing and writing this document. Eliwell reserves the right to make any changes or improvements without prior notice and at any time.

Eliwell & Controlli s.r.l.

Via dell'Industria, 15 Zona Industriale Paludi
32010 Pieve d'Alpago (BL) ITALY
Telephone +39 0437 986111
Facsimile +39 0437 989066
Internet <http://www.eliwel.it>

Technical Customer Support:

Telephone +39 0437 986300
Email: techsuppeliwell@invensys.com

Invensys Controls Europe
An Invensys Company



cod. 9IS44009

04-05 GB

IC 915 LX

MECHANICAL ASSEMBLY

The unit has been designed for panel-mounting: Drill a 29x71 mm hole, insert a tool and fix it in place with the brackets provided. Do not assemble the instrument in excessively humid or dirty locations since it is designed to be used in locations with normal pollution levels. Always make sure that the area next to the cooling openings of the tool is adequately ventilated.

ELECTRICAL CONNECTIONS

Warning! Always switch off machine before working on electrical connections. The instrument has screw terminals for connecting electrical cables with a maximum diameter of 2.5 mm² (only one conductor per terminal for power connections): for terminal capacity, see instrument label. The relay contacts are voltage-free. Do not exceed the maximum current allowed. For higher loads, use a suitable contactor. Make sure that the power voltage complies with the device voltage. The sensor has no connection polarity and can be extended using an ordinary bipolar cable (note that extending the probe may affect the electromagnetic compatibility (EMC) of the instrument: special care must be used when wiring). Probe cables, power supply cables and the TTL serial cable should be kept separate from power cables.

TELEVIS SYSTEM

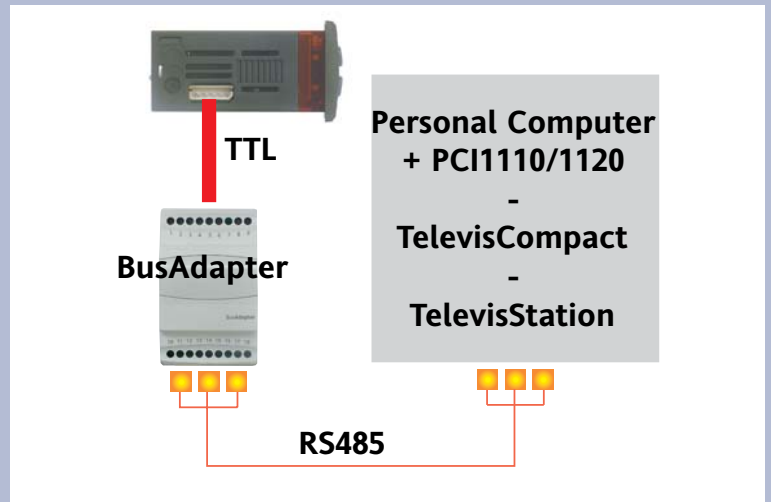

The Televis remote control systems can be connected using the TTL serial port (the 130 or 150 485 BUS ADAPTER TTL-RS interface module must be used). To configure the instrument to do this, you need to access the "Add" folder and use the "dEA" and "FAA" parameters.

The technical characteristics in this document concerning measurements (range, accuracy, resolution, etc.) refer to the instrument in the strictest sense and not to any accessories provided such as probes, for example. This means, for example, that an error introduced by the probe is added to any error that is typical of the instrument.

CONDITIONS OF USE

PERMITTED USE

For safety reasons the instrument must be installed and used in accordance with the instructions supplied. Users must not be able to access parts with dangerous voltage levels under normal operating conditions. The device must be suitably protected from water and dust according to the specific application and only be accessible using special tools (except for the front keypad). The device can be fitted to equipment for household use and/or similar use in the refrigeration sector and has been tested with regard to safety in accordance with the European harmonized reference standards: it is classified as follows:

- as an automatic electronic control device to be integrated as regards its construction;
- as a 1 B type operated control device as regards its automatic operating features;
- as a Class A device in relation to the category and structure of the software.

UNPERMITTED USE

The use of the unit for applications other than those described above is forbidden. It should be noted that the relay contacts supplied with the device are functional and therefore exposed to potential faults. Any protection devices required to comply with product requirements or dictated by common sense due to obvious safety reasons should be installed externally.